

PAL Pro 39 Mechanics Truck Ford 2022 F-550



SuperCab 4x4 Diesel

FORD

PAL PRO 39 MECHANICS TRUCK 2022 F-550 SUPERCAB 4X4 DIESEL

STOCK NUMBER: PALPRO39

NEW

ARRIVING SOON



OFFER INFORMATION

Location details

5125 Clay Ave. SW, Grand Rapids, MI, 49548 -
United States 

Dealer Name

Royal Truck & Utility Trailer

Availability

Arriving Soon

Product type

New

Stock number

PALPRO39

Contact person

AJ DeLange

Dealer E-mail

ajdelange@royaltrailersales.com

Dealer phone

1-800-858-3659

SuperCab 4x4 Diesel

PAL PRO 39 MECHANICS TRUCK

- 11' long steel mechanics body with raised compartments
- 44" tall compartments with 60" tall 1st and 2nd compartments on the streetside and curbside
- A-60 galvanized steel e-coated body
- Double panel aluminum doors
- 21" workbench bumper with power down outriggers on the rear and integrated 2" hitch receiver
- Removable vise mounting bracket on the right rear corner
- LED compartment lights and 4 exterior LED work lights
- Welder mounting plate driver side rear
- Integrated mounted plates on the top of the body for air compressor, boom rest, welder, ect.
- LED rear stop/tail/turn lights

SERVICE CRANE TECHNICAL DETAILS

- PALFINGER PSC 6025 Telescopic Service Crane
- 6,000 lb winch rating @ 3' reach. / 1,380 lbs. capacity @ 25' reach and 38,500 ft/lb lifting moment
- 25' hydraulic boom reach
- Wireless fully proportional radio remote controls
- Winch damage prevention system
- Boom support rest

COMPRESSOR TECHNICAL DETAILS

- PRC 45V Hydraulic Rotary Screw Air Compressor
- 45CFM @ 150 PSI
- Integrated oil cooler with fan
- Cold weather climate kit: includes ambient temp sensor and oil heater.
- 6 gallon air receiver under body with ball valve bleeder for moisture

CHASSIS DETAILS

- 2022 Ford F-550 SuperCab 4x4 Diesel
- 6.7L Diesel Engine
- PTO with integrated pump for Ford automatic transmission
- Direct mount hydraulic pump
- Hydraulic oil reservoir mounted in front of the bulkhead. 30-gallon capacity
- Ford Super Duty adapter

MECHANICS BODY

PAL Pro 39

Mechanics Bodies, Service Cranes & Compressors
Built for the Modern Work Truck.

LIFETIME EXCELLENCE





With the best equipment for the job, add a competitive edge to your business in a range of industries. Our mechanics trucks are a reliable partner in: Construction, Roadway, Railway, Agriculture, Oil & Gas, Mining, Utilities and Municipalities.

Add one of our light weight, long reach, and increased lifting capacity cranes, and our lightest in the industry rotary screw hydraulic compressors and you have the strongest, lightest 39,000 ft lbs capacity crane package.

APPLICABLE CRANE MODELS

- PSC 3216
- PSC 4016
- PSC 4025
- PSC 5025
- PSC 6025

APPLICABLE COMPRESSORS

- PRC 45V
- PRC 60V

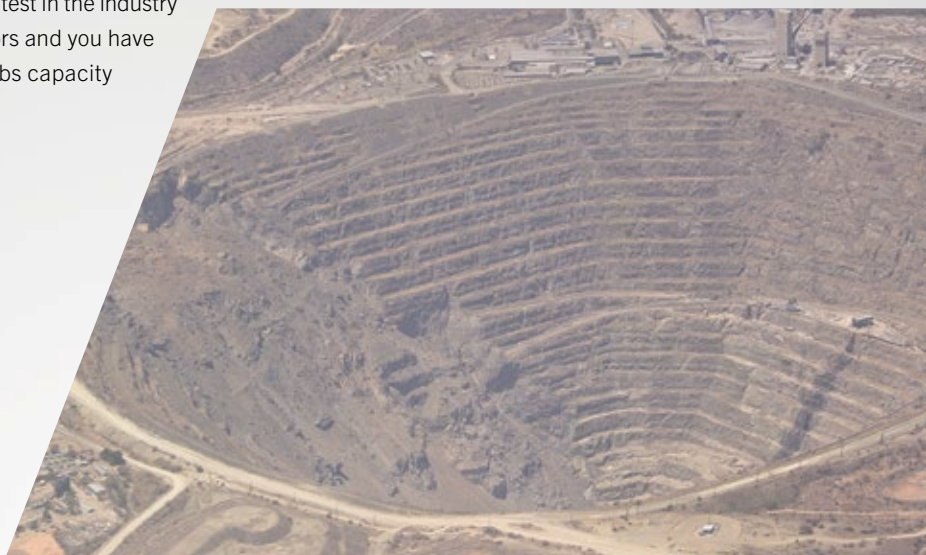

HIGHLIGHTS

Extending the PALFINGER range of mechanics bodies, the PAL Pro 39 is a weight optimized mechanics body available in 9' or 11' configurations. With light-weight aluminum doors and shelving, the PAL Pro 39 offers more usable payload, combined with a stronger, longer and lighter crane. Plus, more standard options are available to meet your service truck needs including headache rack, accessory mounting options, additional tail shelf options and more. PAL Pro 39 is manufactured with 12-gauge all A-60 galvaneal steel construction, a hybrid torsion box that eliminates frame and side pack deflection and the best rust protection in the industry.

NON-MARRING BOOM REST

Optional fixed or adjustable non-marring boom support E-coated black.



LINE-X ULTRA INTERIOR COMPARTMENT COATING FOR GREATER PROTECTION

LINE-X Ultra provides the ultimate protection for your compartment interiors. It resists the damage commonly caused by tools, chains and parts, and prevents the rust that comes as a result. As an added bonus, the coating is white in color and helps to brighten up the interior.

DOOR DESIGN ELIMINATE WELDING

Double panel doors with internal C-channel stiffeners, adhered with structural adhesive.

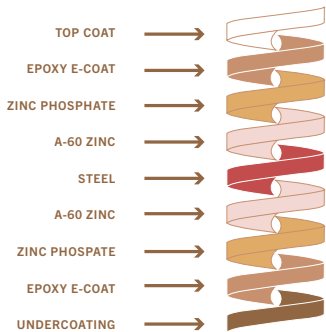

E-COAT CORROSION PROTECTION

PALFINGER's 12 step electrophoretic deposition dip process cleans the body and applies primer to the metal surfaces, ensuring complete coverage and automotive grade corrosion protection.

ALUMINUM DOORS & TRAYS LIGHT-WEIGHT & CORROSION RESISTANT

PALFINGER's unique automotive adhesive bonded two-piece doors, hinges, and compartment divider trays are now all in aluminum. This means increased payload capacity.

RAISED COMPARTMENT REINFORCEMENTS STRUCTURAL INTEGRITY

Every raised compartment comes with our engineered structural gussets to prevent against body cracking in the door corners.

FEATURES



HYBRID TORSION BOX BUILT FOR CRANES

Designed from the start for crane applications and utilizing 12ga A-60 galvanneal steel, the hybrid torsion box eliminates truck frame twist and side pack deflection.

STRUCTURAL CROSS-MEMBERS PAYLOAD SUPPORT

Tubular 3" x 5" structural steel cross-members interlace the torsion box to support compartment loads.

OUTRIGGER HOUSING INTEGRATED LIFTING SUPPORT

Integrated outrigger tube reduces stress on chassis frame by transferring the crane load directly to the ground.

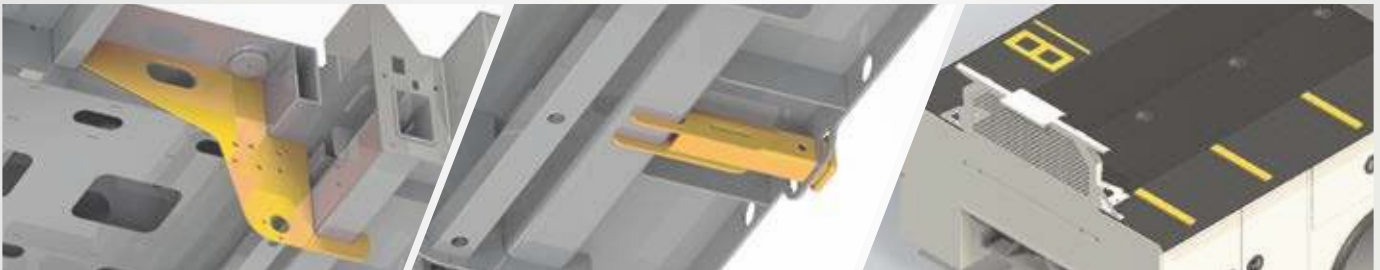

REAR SHEAR PLATE BODY MOUNTS SECURE AND SUPPORTIVE MOUNTING

Steel plates prevent lateral body shift on chassis, providing additional support for crane loads.

INTEGRATED HITCH RECEIVER CLASS 5 RECEIVER

2" I.D. receiver tube, attached directly to body structure. 16,000 lbs towing capacity.

THREADED WELDMENT OPTIONS TO PROTECT YOUR BODY

Boom rest, welder, compressor, EnPak, Air-n-Arc and AirPak mounts are available from the factory to eliminate the need to drill holes in the body.



WORK BENCH BUILT FOR YOUR HARD WORK

A true mechanics workbench, featuring 12" or 21" work bench bumpers, receiver hitch, 1/4" steel top plate and thru compartment for additional storage. (Pictured 21" pipe trough.)

HEADACHE RACK SAVES COSTLY REPAIRS

This light bar bracket with a punched screen prevents cargo area contents from making contact with the rear window of the cab - saving you from costly rear window repairs & cleanup.

BOLT ON HANDRAIL OPTION FOR ADDED SAFETY

Ergonomically designed handrail option, with a stable surface to grip, for your added security against tripping or slipping hazards.

STANDARD CONFIGURATIONS

39-9

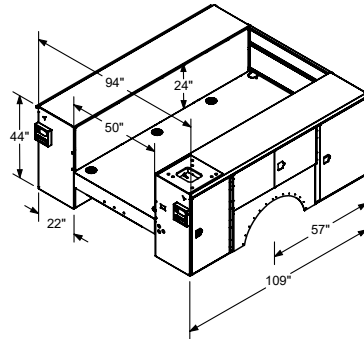

9' standard configuration
 44" tall compartment heights
 14" tall one handed tailgate
 Treadplate compartment top overlays

39-9CS

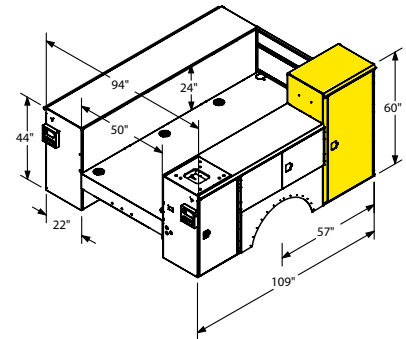

9' standard configuration
 44" tall compartment heights
 CS front compartment raised to 60"
 14" tall one handed tailgate
 Treadplate compartment top overlays
 Reinforced raised compartment

39-9SSCS

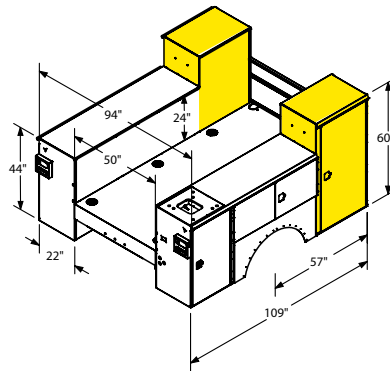

9' standard configuration
 44" tall compartment heights
 SS & CS front compartments raised to 60"
 14" tall one handed tailgate
 Treadplate compartment top overlays
 Reinforced raised compartments

39-11

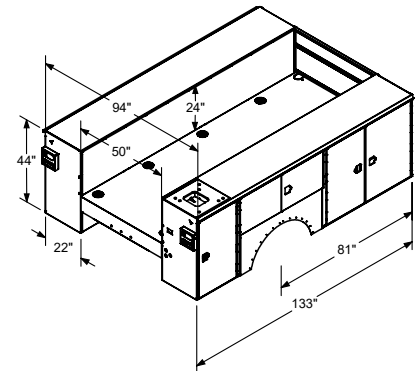

11' standard configuration
 44" tall compartment heights
 14" tall one handed tailgate
 Treadplate compartment top overlays

39-11CS

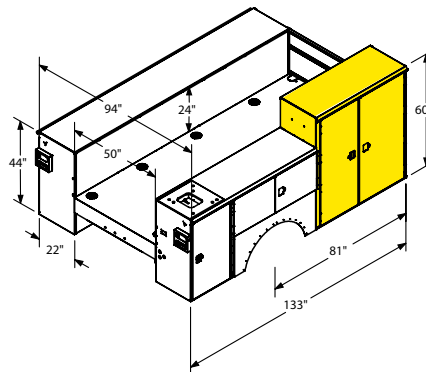

11' standard configuration
 44" tall compartment heights
 CS front compartments raised to 60"
 14" tall one handed tailgate
 Treadplate compartment top overlays
 Reinforced raised compartment

39-11SSCS

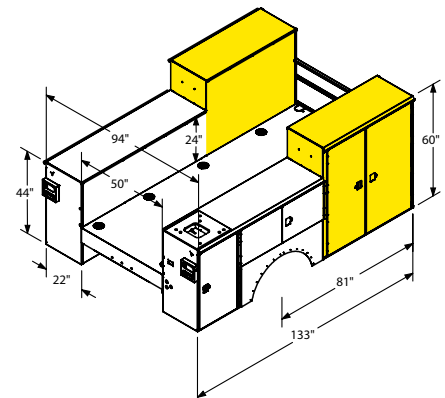

11' standard configuration
 44" tall compartment heights
 SS & CS front compartments raised to 60"
 14" tall one handed tailgate
 Treadplate compartment top overlays
 Reinforced raised compartments

SERVICE CRANE

PRODUCT RANGE

TECHNICAL SPECIFICATIONS

MODEL	CAPACITY	RATED LIFTING MOMENT	MAX LIFTING MOMENT	BOOM EXTENSIONS	BOOM LENGTH	WINCH SPEED	STANDARD WEIGHT	CHASSIS SPECIFICATION
PSC 3216 E	4,000 lbs. (1,814 kg)	12,500 ft*lbs. (17 kNm (1.7 mt))	14,560 ft*lbs. (19.6 kNm (2 mt))	1 Hydraulic + 1 Manual (2 Hydraulic Option)	16 ft. (4.9 m)	21.2 ft./min (6.46 m/min)	650 lbs. (295 kg)	Class 3
PSC 3216 H	4,000 lbs. (1,814 kg)	12,500 ft*lbs. (17 kNm (1.7 mt))	14,560 ft*lbs. (19.6 kNm (2 mt))	1 Hydraulic + 1 Manual (2 Hydraulic Option)	16 ft. (4.9 m)	29.7 ft./min (9.05 m/min)	630 lbs. (286 kg)	Class 3
PSC 4016 E	4,000 lbs. (1,814 kg)	18,500 ft*lbs. (25.1 kNm (2.6 mt))	23,235 ft*lbs. (31.4 kNm (3.2 mt))	1 Hydraulic + 1 Manual (2 Hydraulic Option)	16 ft. (4.9 m)	21.2 ft./min (6.46 m/min)	650 lbs. (295 kg)	Class 3
PSC 4016 H	4,000 lbs. (1,814 kg)	18,500 ft*lbs. (25.1 kNm (2.6 mt))	23,235 ft*lbs. (31.4 kNm (3.2 mt))	1 Hydraulic + 1 Manual (2 Hydraulic Option)	16 ft. (4.9 m)	29.7 ft./min (9.05 m/min)	630 lbs. (286 kg)	Class 3
PSC 4025 E	4,000 lbs. (1,814 kg)	18,500 ft*lbs. (25.1 kNm (2.6 mt))	20,585 ft*lbs. (27.9 kNm (2.9 mt))	2 Hydraulic	25 ft. (7.6 m)	21.2 ft./min (6.46 m/min)	1,010 lbs. (458 kg)	Class 3
PSC 4025 H	4,000 lbs. (1,814 kg)	18,500 ft*lbs. (25.1 kNm (2.6 mt))	20,585 ft*lbs. (27.9 kNm (2.9 mt))	2 Hydraulic	25 ft. (7.6 m)	29.7 ft./min (9.05 m/min)	995 lbs. (451 kg)	Class 3
PSC 5025 E	5,000 lbs. (2,268 kg)	32,500 ft*lbs. (44.2 kNm (4.5 mt))	36,360 ft*lbs. (49.3 kNm (5 mt))	2 Hydraulic	25 ft. (7.6 m)	18.8 ft./min (5.73 m/min)	1,170 lbs. (530 kg)	Class 4
PSC 5025 H	5,000 lbs. (2,268 kg)	32,500 ft*lbs. (44.2 kNm (4.5 mt))	36,360 ft*lbs. (49.3 kNm (5 mt))	2 Hydraulic	25 ft. (7.6 m)	56 ft./min (17.07 m/min)	1,155 lbs. (525 kg)	Class 4
PSC 6025 E	6,000 lbs. (2,750 kg)	38,500 ft*lbs. (52.2 kNm (5.3 mt))	42,800 ft*lbs. (58.0 kNm (5.9 mt))	2 Hydraulic	25 ft. (7.6 m)	43.3 ft./min (13.20 m/min)	1,280 lbs. (580 kg)	Class 4
PSC 6025 H	6,000 lbs. (2,750 kg)	38,500 ft*lbs. (52.2 kNm (5.3 mt))	42,800 ft*lbs. (58.0 kNm (5.9 mt))	2 Hydraulic	25 ft. (7.6 m)	51 ft./min (15.54 m/min)	1,230 lbs. (560 kg)	Class 4
PSC 8029 H	8,000 lbs. (3,650 kg)	43,000 ft*lbs. (58.3 kNm (5.9 mt))	49,180 ft*lbs. (66.5 kNm (6.8 mt))	2 Hydraulic	29 ft. (8.9 m)	60 ft./min (18.28 m/min)	2,149 lbs. (975 kg)	Class 5
PSC 10829 H	10,800 lbs. (4,900 kg)	62,000 ft*lbs. (84.1 kNm (8.6 mt))	68,900 ft*lbs. (93.2 kNm (9.5 mt))	2 Hydraulic	29 ft. (8.9 m)	60 ft./min (18.28 m/min)	2,407 lbs. (1,092 kg)	Class 6
PSC 12529 H	12,500 lbs. (5,700 kg)	72,000 ft*lbs. (97.6 kNm (10 mt))	79,450 ft*lbs. (107.7 kNm (11 mt))	2 Hydraulic	29 ft. (8.9 m)	60 ft./min (18.28 m/min)	2,731 lbs. (1,239 kg)	Class 6
PSC 14029 H	14,000 lbs. (6,400 kg)	86,000 ft*lbs. (116.6 kNm (11.9 mt))	94,676 ft*lbs. (128.4 kNm (13 mt))	2 Hydraulic	29 ft. (8.9 m)	60 ft./min (18.28 m/min)	2,833 lbs. (1,285 kg)	Class 7



OSP_PALPRO39_06/20

Cranes shown in the leaflet are partially optional equipped and do not always correspond to the standard version. All PSC models are subject to change as PALFINGER updates, improves, and technologically advances their cranes and the industry.

OMAHA STANDARD PALFINGER
 3501 S. 11th Street | Council Bluffs, IA
 51501-0876 | USA
 T + 1 800 279 2201
 info@palfingerna.com

PALFINGER.COM

ELECTRIC / HYDRAULIC SERVICE CRANE **PSC 6025**

LIGHTER | LONGER | STRONGER

LIFETIME EXCELLENCE



DISCLOSURE: Image does not show the standard shipping package.



BUILT TO LAST

Meeting or exceeding all ASME and OSHA standards, the PSC 6025 can be specified as either an electric/hydraulic or full hydraulic service crane with 6,000 lbs. capacity. Just like all of our service crane models, the PSC 6025 features wireless proportional control and a single weld hexagonal boom design. The crane is exclusively E-coated by PALFINGER for the best rust protection in the industry.



E-COAT PROTECTION

Most rust resistant telescopic crane on the market



MEDIA BLAST

A high quality process that removes any surface imperfections and provides an optimized surface for E-coating.

E-COAT

Automotive grade and environmentally friendly coating process is applied with precision over the entire product ensuring superior corrosion protection.

TOP COAT

All E-coated steel components receive a top coat finish that ensures maximum durability.



LIGHTER.

PALFINGER's service cranes are as much as **30% lighter** than the competition — without sacrificing strength or reach. Less weight means more payload for tools and supplies necessary on the job site.



LONGER.

Up to **30% longer** than the competition, PALFINGER's service cranes have the longest reach in the industry. More reach means fewer setup adjustments on the job site and improved access for those challenging lifts. Standard boom lengths are 16', 25', and 29' depending on the size of the crane.

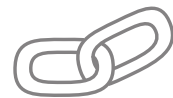

STRONGER.

PALFINGER's service cranes are up to **20% stronger** than the competition, with a superior lifting moment rating and load chart to do more work in more places. With PALFINGER's safety systems, including the exclusive winch damage prevention system, lifting more is also safer than ever before.

STANDARD FEATURES

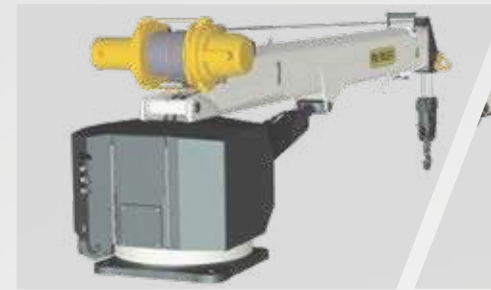

PLANETARY WINCH

Planetary winch provides speed and durability.

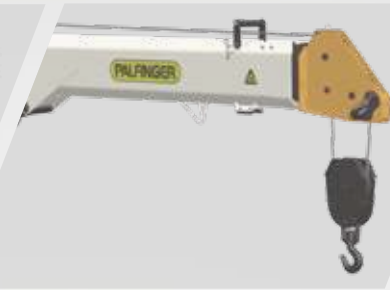

HORSE HEAD

Low profile design. Optional boom tip hook(s) and lights. No A2B components to interfere with operation.



INTELLIGENT WINCH CONSOLE (IWC)

Two-block damage prevention system is integrated into winch mounting platform eliminating the need for boom tip apparatus and cord reel. Complies with ASME B30.5.



LOAD BLOCK STOWING BRACKET

Bracket and pads designed to keep load block from contacting the boom when stowed.

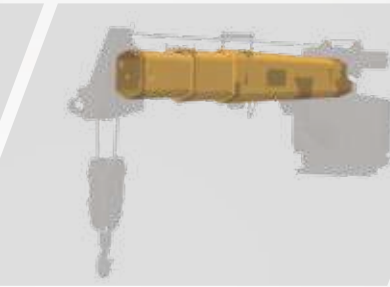

HEXAGONAL BOOMS

Ultra-low maintenance high tensile strength self-centering single weld boom sections powered by internal extension cylinders.



CYLINDERS

Internal extension cylinders for 25' of hydraulically powered outreach. All cylinders are E-coated and use a 5 stage marine grade seal system.



CONTROL SYSTEM

Features a standard proportional wireless remote control unit, integrated E-stop button, warning horn and manual valve activation capability. Cranes are controlled with 12V DC power supply.

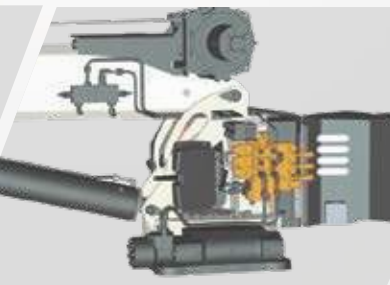

PROPORTIONAL CONTROL

Through the control valve, single function proportional control of all hydraulic functions is standard.

*Fully proportional valve optional



3-YEAR WARRANTY

PALFINGER service cranes come with an industry leading 3-year warranty on all structural components

PERSONNEL BASKET CRANE ACCESSORY

Many optional features are available for PALFINGER service cranes to meet your demands on the job. Contact your PALFINGER Representative to learn more!

PERSONNEL BASKET CRANE ACCESSORY (PATENT PENDING)

Industry-first from PALFINGER designed specifically for service cranes with 5,000 lbs. capacity and above. Quickly set up and attach basket to crane for maximum efficiency on the job. Folds into a compact storage box and mounts onto the body for transport.

Personnel Basket Capacity	300 lbs.
Personnel Basket Weight	280 lbs.
Complete Installation (incl. boxes):	400 lbs.



OPTIONS & ACCESSORIES



ACOUSTIC 90% LOAD WARNING FOR INCREASED SAFETY

An audible warning communicates to the operator that the service crane is working at 90% load capacity and will soon reach maximum capacity.

3RD WRAP LIMITING SYSTEM

Integrated system prevents wire rope spool off, ensuring three wraps remain on drum. Exceeds ASME B30.5.

BOOM TIP HOOK

PALFINGER exclusive 1.5 ton capacity boom tip hook. Available on either or both sides of the boom tip. Horsehead has threaded weldment for mounting.



OUTRIGGERS FOR ADDED STABILITY

Support your lifting application needs with manual and hydraulic outrigger options.

BOOM TIP LIGHTING

With the addition of a retractable cord reel we bring power to the boom tip to light dual work lights that swing freely while raising and lowering the boom to illuminate your working area.

FULLY PROPORTIONAL VALVE

Add true multi-function capability with an upgraded valve for running several crane functions at the same time.



PROTECTIVE CASE WITH BELT LOOP KEEPS REMOTE AT YOUR SIDE

Nylon case with clear plastic cover protects your remote control from harsh weather elements, while the belt loop allows you to attach the remote to your work belt for added convenience on the job.

SILICONE COVER FOR REMOTE KEEPS REMOTE CLEAN

Flexible silicone cover helps keep dust, dirt, and grime off of your remote control – so you can focus on controlling your service crane and not cleaning the remote.

REMOTE STORAGE BRACKET SECURELY STOWS REMOTE

Stow the remote control using the metal storage bracket and mount it in the cab or the crane compartment. Thanks to the remote magnet, the remote will be held securely in place during transport.



TECHNICAL SPECIFICATIONS

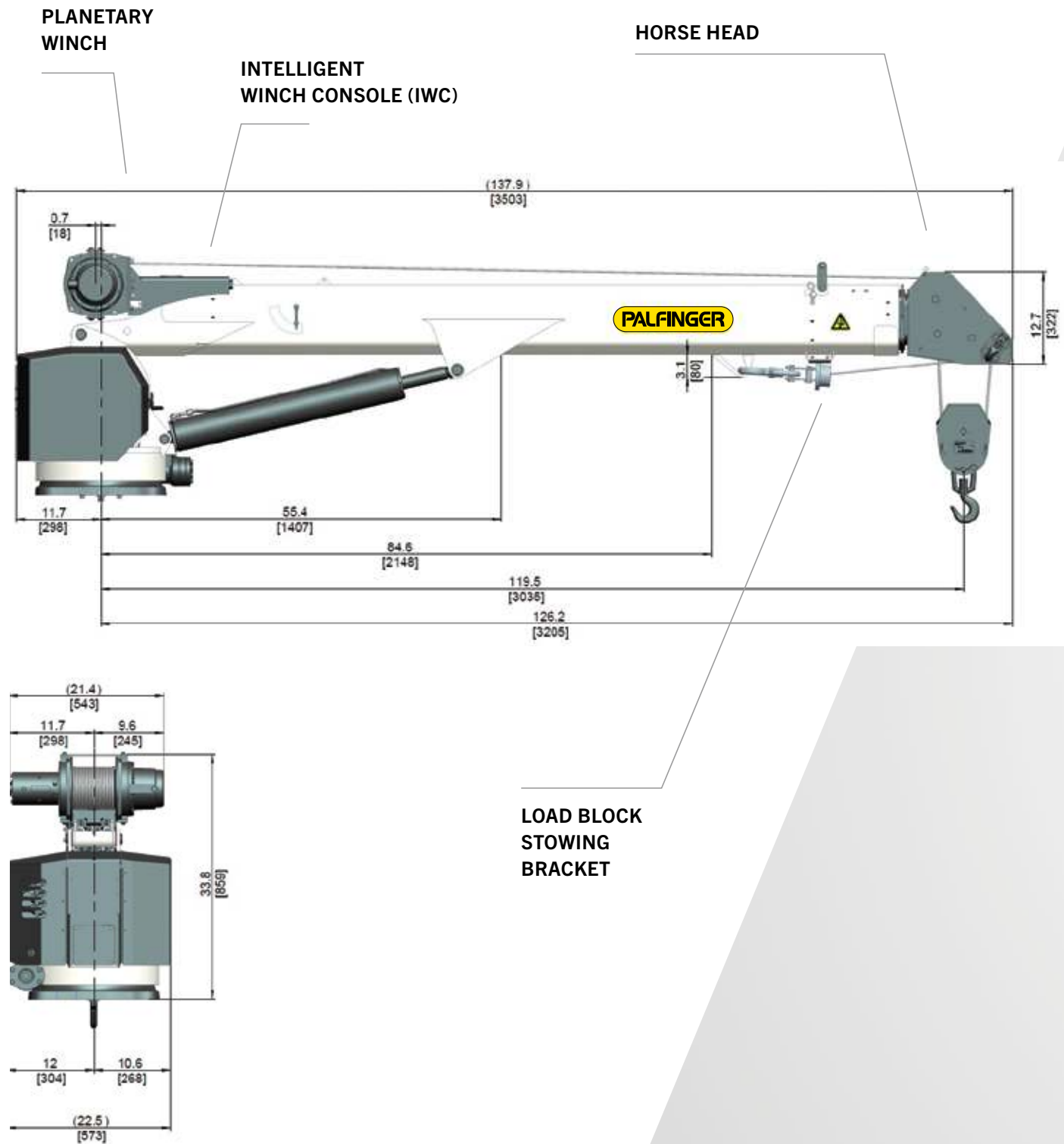

TECHNICAL SPECIFICATIONS

CRANE RATING

Rated lifting moment	38,500 ft*lbs. (52.2 kNm (5.3 mt))
Maximum lifting moment	42,800 ft*lbs. (58 kNm (5.9 mt))
Boom extensions	25 ft. (7.6 m)
	2 hydraulic
Crane weight Electric	1,280 lbs. (580 kg)
Crane weight Hydraulic	1,230 lbs. (560 kg)
Hydraulically powered extensions	

CONTROL SYSTEM

Wireless remote control unit
Integrated E-stop button
Manual emergency valve activation capability
Integrated warning horn
12V DC power supply

ROTATION SYSTEM

Slewing torque	5,545 ft*lbs (7.5 kNm (0.8 mt))
Slewing angle Electric	Continuous rotation
Slewing angle Hydraulic	410 ° rotation

STANDARDS (meets or exceeds)

Crane design	ASME B30.5	OSHA 1910.28
Calculation	EN 12999 H1,B6	

PLANETARY GEAR WINCH

Max. winch force single line	3,000 lbs. (1,375 kg)
Max. winch force double line	6,000 lbs. (2,750 kg)
Max. line speed Electric	43.3 ft./min (13.20 m/min)
Max. line speed Hydraulic	51 ft./min (15.54 m/min)
Cable size and length	5/16" x 95' (7.9 mm x 28.9 m)
Two-block damage prevention system	
3rd wrap end stop system option	

HYDRAULIC SYSTEM

Operating pressure	2,800 psi (19.3 Mpa (193 bar))
Required oil flow Hydraulic	5.2 GPM (20 l/min)
Electronic overload protection system	
Five stage marine-grade seals on all cylinders	
Non integrated load-holding valves on all cylinders	

CRANE | CHASSIS INTERFACE

Base plate dimension	17.75" x 17.75" (450 mm x 450 mm)
Hole pattern	14.75" x 14.75" (375 mm x 375 mm)
Mounting bolts	4 x 1" -8 UNC

CHASSIS RECOMMENDATION

Chassis style	Conventional
Minimum GVWR	Class 4 (14,001 lbs. (6,350 kg))

Weights of load-handling devices are part of the load lifted and must be deducted from the capacity.

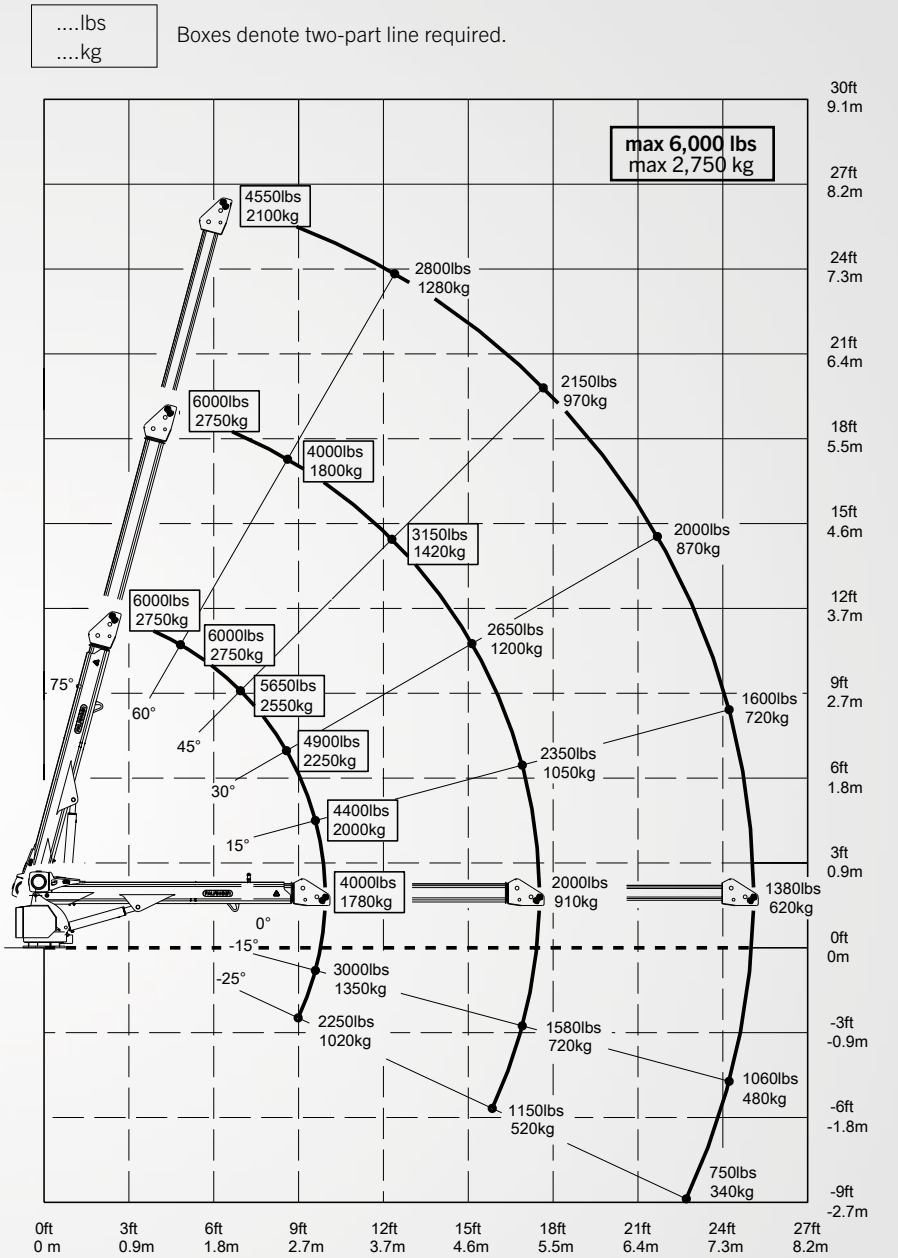

PRODUCT RANGE

TECHNICAL SPECIFICATIONS

MODEL	CAPACITY	RATED LIFTING MOMENT	MAX LIFTING MOMENT	BOOM EXTENSIONS	BOOM LENGTH	WINCH SPEED	STANDARD WEIGHT	CHASSIS SPECIFICATION
PSC 3216 E	4,000 lbs. (1,814 kg)	12,500 ft*lbs. (17 kNm (1.7 mt))	14,560 ft*lbs. (19.6 kNm (2 mt))	1 Hydraulic + 1 Manual (2 Hydraulic Option)	16 ft. (4.9 m)	21.2 ft./min (6.46 m/min)	650 lbs. (295 kg)	Class 3
PSC 3216 H	4,000 lbs. (1,814 kg)	12,500 ft*lbs. (17 kNm (1.7 mt))	14,560 ft*lbs. (19.6 kNm (2 mt))	1 Hydraulic + 1 Manual (2 Hydraulic Option)	16 ft. (4.9 m)	29.7 ft./min (9.05 m/min)	630 lbs. (286 kg)	Class 3
PSC 4016 E	4,000 lbs. (1,814 kg)	18,500 ft*lbs. (25.1 kNm (2.6 mt))	23,235 ft*lbs. (31.4 kNm (3.2 mt))	1 Hydraulic + 1 Manual (2 Hydraulic Option)	16 ft. (4.9 m)	21.2 ft./min (6.46 m/min)	650 lbs. (295 kg)	Class 3
PSC 4016 H	4,000 lbs. (1,814 kg)	18,500 ft*lbs. (25.1 kNm (2.6 mt))	23,235 ft*lbs. (31.4 kNm (3.2 mt))	1 Hydraulic + 1 Manual (2 Hydraulic Option)	16 ft. (4.9 m)	29.7 ft./min (9.05 m/min)	630 lbs. (286 kg)	Class 3
PSC 4025 E	4,000 lbs. (1,814 kg)	18,500 ft*lbs. (25.1 kNm (2.6 mt))	20,585 ft*lbs. (27.9 kNm (2.9 mt))	2 Hydraulic	25 ft. (7.6 m)	21.2 ft./min (6.46 m/min)	1,010 lbs. (458 kg)	Class 3
PSC 4025 H	4,000 lbs. (1,814 kg)	18,500 ft*lbs. (25.1 kNm (2.6 mt))	20,585 ft*lbs. (27.9 kNm (2.9 mt))	2 Hydraulic	25 ft. (7.6 m)	29.7 ft./min (9.05 m/min)	995 lbs. (451 kg)	Class 3
PSC 5025 E	5,000 lbs. (2,268 kg)	32,500 ft*lbs. (44.2 kNm (4.5 mt))	36,360 ft*lbs. (49.3 kNm (5 mt))	2 Hydraulic	25 ft. (7.6 m)	18.8 ft./min (5.73 m/min)	1,170 lbs. (530 kg)	Class 4
PSC 5025 H	5,000 lbs. (2,268 kg)	32,500 ft*lbs. (44.2 kNm (4.5 mt))	36,360 ft*lbs. (49.3 kNm (5 mt))	2 Hydraulic	25 ft. (7.6 m)	56 ft./min (17.07 m/min)	1,155 lbs. (525 kg)	Class 4
PSC 6025 E	6,000 lbs. (2,750 kg)	38,500 ft*lbs. (52.2 kNm (5.3 mt))	42,800 ft*lbs. (58.0 kNm (5.9 mt))	2 Hydraulic	25 ft. (7.6 m)	43.3 ft./min (13.20 m/min)	1,280 lbs. (580 kg)	Class 4
PSC 6025 H	6,000 lbs. (2,750 kg)	38,500 ft*lbs. (52.2 kNm (5.3 mt))	42,800 ft*lbs. (58.0 kNm (5.9 mt))	2 Hydraulic	25 ft. (7.6 m)	51 ft./min (15.54 m/min)	1,230 lbs. (560 kg)	Class 4
PSC 8029 H	8,000 lbs. (3,650 kg)	43,000 ft*lbs. (58.3 kNm (5.9 mt))	49,180 ft*lbs. (66.5 kNm (6.8 mt))	2 Hydraulic	29 ft. (8.9 m)	60 ft./min (18.28 m/min)	2,149 lbs. (975 kg)	Class 5
PSC 10829 H	10,800 lbs. (4,900 kg)	62,000 ft*lbs. (84.1 kNm (8.6 mt))	68,900 ft*lbs. (93.2 kNm (9.5 mt))	2 Hydraulic	29 ft. (8.9 m)	60 ft./min (18.28 m/min)	2,407 lbs. (1,092 kg)	Class 6
PSC 12529 H	12,500 lbs. (5,700 kg)	72,000 ft*lbs. (97.6 kNm (10 mt))	79,450 ft*lbs. (107.7 kNm (11 mt))	2 Hydraulic	29 ft. (8.9 m)	60 ft./min (18.28 m/min)	2,731 lbs. (1,239 kg)	Class 6
PSC 14029 H	14,000 lbs. (6,400 kg)	86,000 ft*lbs. (116.6 kNm (11.9 mt))	94,676 ft*lbs. (128.4 kNm (13 mt))	2 Hydraulic	29 ft. (8.9 m)	60 ft./min (18.28 m/min)	2,833 lbs. (1,285 kg)	Class 7



PROUDLY ASSEMBLED
in the USA

OSP-PSC6025 | 06/20

Cranes shown in the leaflet are partially optional equipped and do not always correspond to the standard version. All PSC models are subject to change as PALFINGER updates, improves, and technologically advances their cranes and the industry.

OMAHA STANDARD PALFINGER
3501 S. 11th Street | Council Bluffs, IA
51501-0876 | USA
T + 1 800 279 2201
info@palfingerna.com

PALFINGER.COM